

Installation Instructions

Ground Fixed

Bell Lyre
Page 1 of 2



Instrument Components:



x4

M6x20 Security Screw



x2

M6 Saddle Strap

Metric Conversion:
250mm/ 10"
600mm/ 24"
1.5m/ 59"
1525mm/ 60"

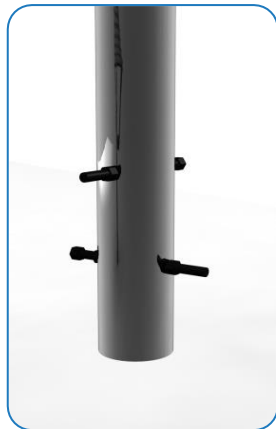

Weight of heaviest part **14.4kg** (Bell Lyre)

1. Attach Ground Fixing posts to legs. (1.2) (See Ground Fix Post Installation Sheet)

2. Excavate 1 hole for the Steel leg 250mm diameter by 600mm deep, in desired location upon decision from customer.

3. Locate (lower) legs into hole making sure they are vertical and level prior to concreting in place.

4. Once happy with location of the Instrument, **fill** hole using rapid hardening concrete. Be sure to compact concrete around legs and leave to dry according to manufactures guidelines.

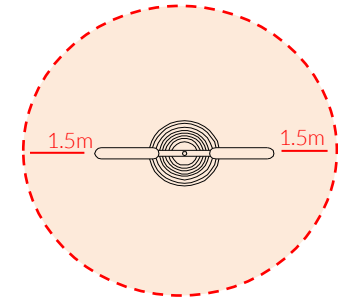

Install Instrument with 1m free space (from widest point) around it.

1900mm

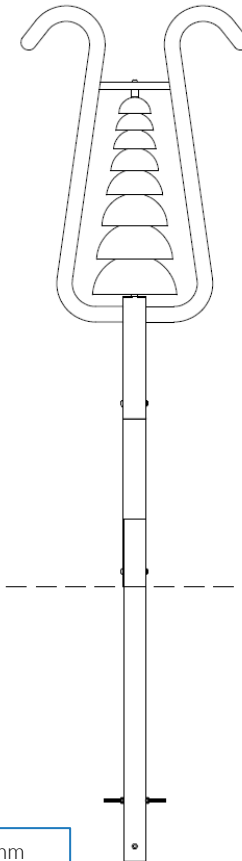

Ground Surface

900mm

CAUTION: Bell Lyre surface can get hot in direct sunlight, if possible install in shaded areas.

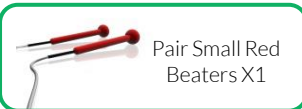

Pair Small Red Beaters X1

Ground Fix Components:



x2

M10x200 Threaded Bar



x4

M10 Nut



x1

M10x70 Security Screw



x1

M10 Barrel Nut



Spares available from percussionplay.com or from your local distributor

23.5 Kg

Ground Fix Post Installation

Ground Fixed

Bell Lyre
Page 2 of 2



Components:



x2

M10x200 Threaded Bar



x4

M10 Nut



x1

M10 Barrel Nut



x1

M10x70 Security Screw

Thread Lock Solution
Required (Not Supplied)



BS EN 1176

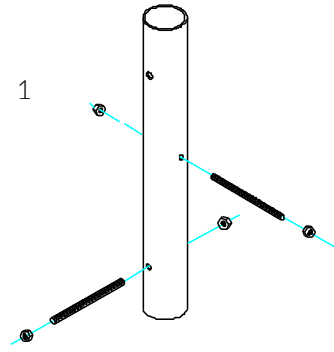

1

Insert M10x 200 Threaded bar into pre drilled holes in Ground Fixing Post

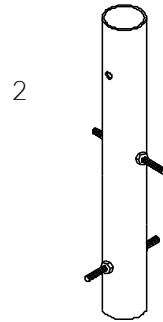

2

Fix M10x 200 Threaded bar in place using M10 Nuts

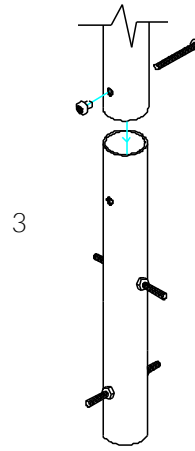

3

Locate the Ground fix Post into the leg of the instrument.

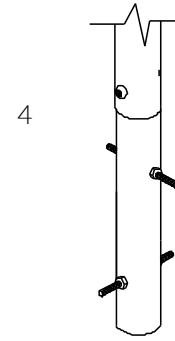

4

Fix instrument to Ground fix post using M10 bolt and Barrel Nut and use **thread locking solution** to prevent fixings working loose.

Thread Lock Solution
Required (Not Supplied)

Tools:

x2
TX 45 Driver Bit

Foundations should not present a hazard. These foundations are recommended as a guide, for more information on foundation details for various surface see Part 1 of BS EN 1176.

Metric Conversion:

50mm/2"
100mm/4"
250mm/10"
350mm/14"
600mm/24"
650mm/26"

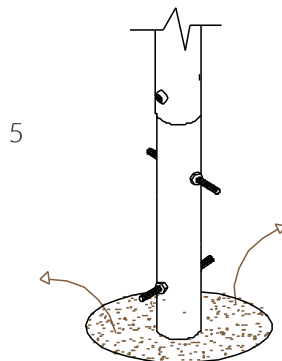

5

Excavate 1 hole with a 250mm diameter tapering down to 350mm diameter and 650mm depth

600mm min depth
Can be buried deeper if required

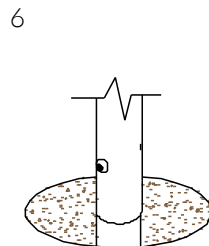

6

Compact base of hole with 50mm of aggregate. Lower ground Fix post attached to instrument into hole (check instrument straight and level before filling with concrete)

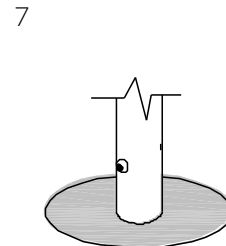

7

Fix hole with fast drying concrete to manufacturers specifications.

